

O. P. JINDAL SCHOOL, SAVITRI NAGAR

SAMPLE PAPER - 08

Class: XII

MM: 70

Subject: Physics

Time: 3 Hrs

General Instruction:-

- (xiii) All questions are compulsory. There are 33 questions in all.
- (xiv) This question paper has five sections: Section A, Section B, Section C, Section D and Section E.
- (xv) Section A contains ten very short answer questions and four assertion reasoning MCQs of 1 mark each, Section B has two case based questions of 4 marks each, Section C contains nine short answer questions of 2 marks each, Section D contains five short answer questions of 3 marks each and Section E contains three long answer questions of 5 marks each.
- (xvi) There is no overall choice. However internal choice is provided. You have to attempt only one of the choices in such questions.
- (xvii) Use of calculators is not permitted. However, you may use log tables, if necessary.
- (xviii) You may use the following physical constant where ever necessary:
- Gravitational constant $G = 6.6 \times 10^{-11} \text{ Nm}^2 \text{ kg}^{-2}$
- Gas constant $R = 8.314 \text{ J mol}^{-1} \text{ K}^{-1}$
- Mass of electron $= 9.110 \times 10^{-31} \text{ kg}$
- Mechanical equivalent of heat $= 4.185 \text{ J cal}^{-1}$
- Standard atmospheric pressure $= 1.013 \times 10^5 \text{ Pa}$
- Absolute zero (0 K) $= -273.15^\circ \text{C}$
- Acceleration due to gravity $= 9.8 \text{ ms}^{-2}$

SECTION-A

All questions are compulsory. In case of internal choices, attempt anyone of them.

1. The refractive indices of glass and water with respect to air are $\frac{3}{2}$ and $\frac{4}{3}$, respectively. Then, calculate the refractive index of glass with respect to water.

Or

In a plano-convex lens, the radius of curvature of convex surface is 10 cm and the focal length of the lens is 30 cm. Then, calculate the refractive index of the material of the lens.

2. Proton and electron have same kinetic energy. If wavelength associated with protons and electrons are λ_p and λ_e respectively, then find out the relation between λ_p and λ_e .
3. Why do stable nuclei never have more protons than neutrons?
4. If two parallel current-carrying conductors placed 1 m apart in vacuum are placed such that each carries 2 A current, then calculate the force due to them.

Or

Calculate the current drawn by the primary coil of a transformer which steps down from 220 V to 22 V with secondary coil of impedance of 220Ω .

- * You are advised to attempt this sample paper without referring the solutions given here. However, cross check your solutions with the solutions given at the end of paper after you complete the paper.

5. A Physics teacher of class 12th was explaining the topic electric field lines. She then told the class that, at some locations, electric field due to two identical negative charges can be zero. How?

Or

An arbitrary surface encloses a dipole. What is the electric flux through this surface?

6. At low temperatures, pure semiconductors act as an insulators. Why?

Or

n -type material is electrically neutral even through $n_e \gg n_h$. Why?

7. Why lighter elements are better moderators for a nuclear reactor than heavier elements?
8. Electrostatic field lines do not form closed loops. Give reason.
9. Why macroscopic objects in our daily life do not show wave properties?
10. What is the difference in the charge carriers in a semiconductor and conductor?

For question numbers 11, 12, 13 and 14, two statements are given-one labelled

Assertion (A) and the other labelled **Reason (R)**. Select the correct answer to these questions from the codes (a), (b), (c) and (d) as given below.

- (a) Both A and R are true and R is the correct explanation of A.
- (b) Both A and R are true but R is not the correct explanation of A.

- (c) A is true but R is false.
- (d) A is false and R is also false.

11. **Assertion** A positive point charge initially at rest in a uniform electric field starts moving along electric lines of force. (Neglect all other forces except electric forces).

Reason A point charge released from rest in an electric field always moves along the line of force.

12. **Assertion** A parallel plate capacitor is connected across a battery through a key. A dielectric slab of dielectric constant K is introduced between the plates. The electric field inside the capacitor becomes K times.

Reason The surface density of charge on the plate remains constant or unchanged.

13. **Assertion** For $\nu > \nu_0$ (threshold frequency), photoelectric current is proportional to intensity.

Reason Greater the number of energy quanta available, greater is the number of electrons absorbing the energy quanta and greater is the number of electrons coming out of the metal.

14. **Assertion** Photodiodes are operated under reverse bias.

Reason Current in forward bias is known to more ($\sim \text{mA}$) than the current in reverse bias ($\sim \mu\text{A}$).

SECTION-B

Questions 15 and 16 are case study based questions and are compulsory. Attempt any 4 sub parts from each question. Each question carries 1 mark.

Refraction of Light

15. Refraction involves change in the path of light due to change in the medium.

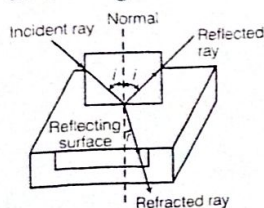

When a beam of light encounters another transparent medium, a part of light gets reflected back into the first medium while the rest enters the other. The direction of propagation of an obliquely incident ray of light, that enters the other medium, changes at the interface of two media. This phenomenon is called refraction of light.

- (i) Which of the following quantity remains unchanged after refraction?
- (a) Speed of light
 (b) Intensity of light
 (c) Wavelength of light
 (d) Frequency of light
- (ii) A ray of light strikes an air-glass interface at an angle of incidence ($i = 60^\circ$) and gets refracted at an angle of refraction r . On increasing the angle of incidence ($i > 60^\circ$), the angle of refraction r
- (a) decreases (b) remains same
 (c) is equal to 60° (d) increases
- (iii) When an object lying in a denser medium is observed from rarer medium, then real depth of object is
- (a) more than that observed
 (b) less than that observed
 (c) equals to observed depth
 (d) depends on angle of vision
- (iv) For the same angle of incidence, the angles of refraction in media P, Q and R are $35^\circ, 25^\circ$ and 15° , respectively. Which of the following relation hold true for the velocity of light in medium P, Q and R ?
- (a) $v_P < v_Q < v_R$ (b) $v_P < v_R < v_Q$
 (c) $v_P > v_Q > v_R$ (d) $v_P > v_R > v_Q$

- (v) A light ray enters from medium A to medium B as shown in figure. The refractive index of medium B relative to A will be

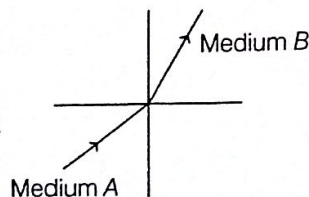

- (a) greater than unity (b) less than unity
 (c) equal to unity (d) zero

Faraday's Laws

16. According to Faraday's first law, whenever the amount of magnetic flux linked with a circuit changes, an emf is induced in it. Induced current is determined by the rate at which the magnetic flux changes.

Mathematically, the magnitude of the induced emf in a circuit is equal to the rate of change of magnetic flux through the circuit.

Induced emf \propto Rate of change of magnetic flux

- (i) On the basis of Faraday's law, current in the coil is larger

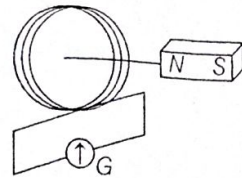

- (a) when the magnet is pushed towards the coil faster
 (b) when the magnet is pulled away from the coil faster
 (c) Both (a) and (b)
 (d) Neither (a) nor (b)
- (ii) The flux linked with a circuit is given by $\phi = t^3 + 3t - 7$. The graph between time (X-axis) and induced emf (Y-axis) will be a
- (a) straight line through the origin
 (b) straight line with positive intercept
 (c) straight line with negative intercept
 (d) parabola not through the origin
- (iii) Wire loop is rotated in a magnetic field. The frequency of change of direction of the induced emf is
- (a) once per revolution
 (b) twice per revolution
 (c) four times per revolution
 (d) six times per revolution
- (iv) The instantaneous magnetic flux linked with a coil is given by $\phi = (5t^3 - 100t + 300)$ Wb. The emf induced in the coil at time $t = 2$ s is
- (a) -40 V (b) 40 V (c) 140 V (d) 300 V
- (v) A copper disc of radius 0.1 m is rotated about its centre with 20 rev/s in a uniform magnetic field of 0.1 T with its plane perpendicular to the field. The emf induced across the radius of the disc is
- (a) $\frac{\pi}{20}$ V (b) $\frac{\pi}{10}$ V
 (c) 20π mV (d) None of these

SECTION-C

All questions are compulsory. In case of internal choices, attempt anyone.

17. It is estimated that the atomic bomb exploded at Hiroshima released a total energy 7.6×10^{13} J. If on an average 200 MeV energy was released by fission of one ${}_{92}^{235}\text{U}$ atom, calculate
- the number of uranium atoms fissioned
 - the mass of uranium used in the bomb.

Or

The value of ground state energy of hydrogen atom is -13.6 eV.

- What does the negative sign signify?
 - How much energy is required to take an electron in this atom from the ground state to the first excited state?
18. If a compass box and a dip circle were taken to the magnetic north pole of the earth, what would one observe with regard to the direction of their respective needle and why?
19. Upto what voltage will the capacitor C in the figure given below be charged? (Internal resistance of the cell E is negligible)

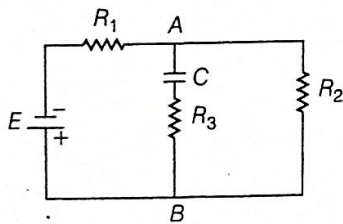

20. Draw energy band diagram of n -type and p -type semiconductor.
21. Use Kirchhoff's laws to determine the value of I_1 in the electrical circuit given below

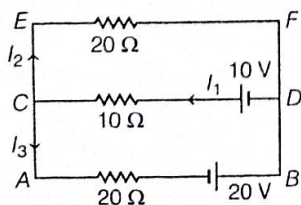

Or

The given figure shows the experimental set-up of a metre bridge. The null point is found to be 60 cm away from the end A with X and Y in position as shown. When a resistance of 15Ω is connected in series with Y , the null point is found to shift by 10 cm towards the end A of the wire. Find the position of null point, if a resistance of 30Ω were connected in parallel with Y .

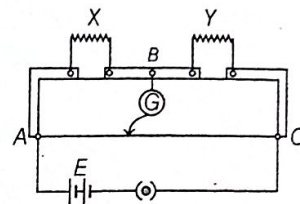

22. Draw a labelled ray diagram of an astronomical telescope, forming the image at infinity. An astronomical telescope uses two lenses of powers 10D and 1D. State with reason, which lens is preferred of objective and eyepiece.

Or

A ray of light is incident at an angle of 60° on one face of a rectangular glass slab of thickness 0.1 m and refractive index 1.5. Calculate the lateral shift produced.

23. Derive an expression for self-inductance of a long air-cored solenoid of length l , cross-sectional area A and having number of turns N .
24. (i) Arrange X-rays, ultraviolet rays and visible light according to their energy.
(ii) Mention one property that is common and one property that is different for all electromagnetic waves. Write an expression relating this property to medium properties.
25. (i) Name the special purpose diode used for detecting optical signals. How does it detect optical signals?
(ii) How is it biased and why?

SECTION-D

All questions are compulsory. In case of internal choices, attempt any one.

26. A particle moving with velocity 5×10^6 m/s has de-Broglie wavelength of 0.135 nm associated with it.
- In which region of the electromagnetic spectrum does this wavelength lie?
 - Calculate its kinetic energy in eV.
27. In a chamber, a uniform magnetic field of 8.0 G ($1\text{G} = 10^{-4}$ T) is maintained. An electron with a speed of 4.0×10^6 ms⁻¹ enters the chamber in a direction normal to the field.
- Describe the path of the electron.
 - What is the frequency of revolution of the electron?

Or

A magnetic dipole is under the influence of two magnetic fields. The angle between the field directions is 60° and one of the fields has a magnitude of 1.2×10^{-2} T.

If the dipole comes to stable equilibrium at an angle of 15° with this field, then what is the magnitude of the other field?

28. We know the empirical formula for observed wavelength in hydrogen spectrum is given by

$$\frac{1}{\lambda} = R \left(\frac{1}{n_1^2} - \frac{1}{n_2^2} \right)$$

where, R = Rydberg's constant,

n_1 = principal quantum number of lower energy level

and n_2 = principal quantum number of higher energy level.

Use it to show that the shortest wavelength lines in Lyman, Balmer and Paschen series have their wavelengths in the ratio 1 : 4 : 9.

29. In Young's double slit experiment, the width of fringes obtained with light of wavelength 6000 \AA is 2 mm. What will be the fringe width, if the entire apparatus is

immersed in a liquid of refractive index 1.33? Also, explain how the location of the maxima will be affected.

Or

A convex lens of focal length 10 cm is placed coaxially 5 cm away from a concave lens of focal length 10 cm. If an object is placed 30 cm in front of the convex lens, find the position of the image formed by the combined system.

If now this system of lens are kept in contact with each other, then find the focal length of the system.

30. Two cells of voltages 30V and 6V and internal resistances 6Ω and 3Ω respectively are connected as shown below

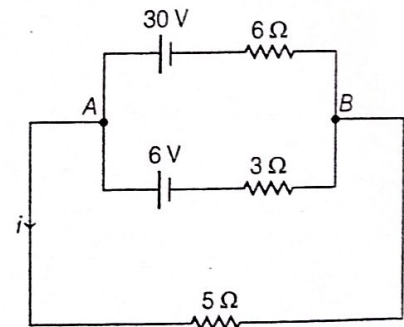

Using Kirchhoff's rules, we can find current (i) and potential across each cell as by assuming current in different part as shown

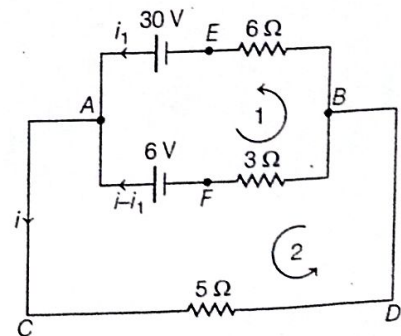

For loop 1, i.e. AFBE

$$-6 + 3(i - i_1) - 6i_1 + 30 = 0$$

$$\Rightarrow 3i - 3i_1 - 6i_1 = -24$$

$$\text{or} \quad i - 3i_1 = -8 \quad \dots(i)$$

For loop 2, i.e. ACDBFA

$$-5i - 3(i - i_1) + 6 = 0$$

$$\Rightarrow -8i + 3i_1 = -6 \quad \dots(ii)$$

Solving Eqs. (i) and (ii), we get

$$\Rightarrow -7i = -14$$

$$\Rightarrow i = 2\text{A}$$

$$\text{and} \quad V_A - V_B = 5i \\ = 5 \times 2 = 10\text{V}$$

For the given circuit diagram, suggest an alternative method to calculate these values.

SECTION-E

All questions are compulsory. In case of internal choices, attempt anyone.

31. A ray of light goes from medium 1 to medium 2. Velocity of light in the two media are c_1 and c_2 , respectively. For an angle of incidence θ in medium 1. The corresponding angle of refraction in medium 2 is $\theta/2$.

- Which of the two media is optically denser and why?
- Establish the relationship among θ , c_1 and c_2 .
- The critical angle of incidence in a glass slab placed in air 45° . What will be the critical angle when it is immersed in water of refractive index 1.33?

Or

- State Huygens' principle. Using this principle, draw a diagram to show how a plane wavefront incident at the interface of two media gets refracted when it propagates from a rarer to a denser medium. Hence, verify Snell's law of refraction.
 - Is the frequency of reflected and refracted light same as the frequency of incident light?
32. (i) State the conditions for resonance to occur in a series $L-C-R$ circuit. Derive an expression for resonant frequency.
- (ii) Draw a graph showing the variation of peak current (i_m) with frequency of AC source. Define the quality factor of the circuit. Write its significance and how can you improve the quality factor of a series resonance circuit.

Or

- Describe briefly with the help of a labelled diagram, the working of a step-up transformer.

- Write any two sources of energy loss in a transformer.
- A step-up transformer converts a low voltage into high voltage. Does it not violate the principle of conservation of energy? Explain.

33. Given figure shows a charge array known as an electric quadrupole. For a point on the axis of the quadrupole, obtain the dependence of potential on r for $r/a \gg 1$ and contrast your results with that due to an electric dipole and an electric monopole (i.e. a single charge).

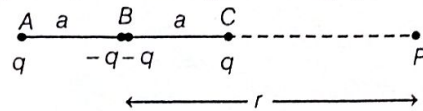

Or

- Describe schematically the equipotential surfaces corresponding to
 - a constant electric field in the z -direction,
 - a field that uniformly increases in magnitude but remains in a constant (say- z) direction and
 - a single positive charge at the origin.
- A spherical conductor of radius 12 cm has a charge of 1.6×10^{-7} C distributed uniformly on its surface.
 - What is the electric field
 - at a point 18 cm from centre of conductor
 - and inside the conductor?
 - What is the electric potential
 - on its surface
 - and inside it?